



Preparation Designing and Optimizing Control of Central Chiller Plant for High-Rise Buildings

Nguyen Huy Phuong, Phan Quy, and Bui Dang Thanh*

Abstract— This paper presents an approach for analyzing, designing and optimizing control for central chiller plant system, in a centralized air-conditioning system using chillers. The optimization control program is implemented on the Building Management System (BMS) from Siemens provider. The optimal control approach is relied on analyzing chiller's machine principle and performance characteristics curve, the flow rate per capacity of chiller's condenser and evaporator, the temperature of chilled water supply and condenser water supply, real data of pump's flow rate. The program permits a stabilized control and operates the plant around the optimum point of all equipment's, in the chilled water circulation as well as condenser's cooling water circulation. The system, therefore, reduces an investor's total life-cycle cost and effectively contributes the energy efficiency and save the global environment. The tested data in one building complex showed the good performance of the program and saving electrical consumption.

Keywords— Chiller plant, COP, optimization control, software module, building management system.

1. INTRODUCTION

It is known that energy conservation efforts made to reduce the consumption of energy. This can be achieved either by using energy more efficiently or by reducing the amount of services. Reducing the amount of services normally leads to cut-down of convenience delivered to users [1]. Meanwhile, using the energy efficiently keeps the convenience unchanged. Thus, the second method is obviously society's preferable [2].

It has been shown that human uses about 50% to 60% the energy in the building for Heating Ventilation and Air Conditioning (HVAC) services [3]. In the high-rise building which used central chiller air-conditioning system, most of energy consumption is at chilled water production plant. In many facilities existed around the world changing the HVAC design or upgrading the machines tends to be an expensive solution. Thus, the best way is to make the system operated efficiently or optimized in energy consumption [4]. Though, there are many studies on the chilled water production plant energy saving and optimization in the literature, there is not a complete system that can automatically optimized software, technical analysis, and control method.

In this study, we try to design an automatically controlled chilled water plant system via implementing the software in a BMS. The designed system includes an integration controller, a direct digital controller, a human machine interface, all connected on a building automation BACnetIP network. We use a dedicated controller in this application to replace other conventional microcontrollers in temperature control [5]

for reasons such as improving reliability and increasing stability of the system. The powers process control language (PPCL) from Siemens is used for implementation of sequential function chart. Optimized control program has been implemented in a Hotel-Office-Resident complex in Hanoi, at the first step. The preliminary results show that, the designed system saves about 9.1% energy at the optimization. The results obtained in this study clearly show the effectiveness of the optimal control applied to the chiller system in practice.

2. SYSTEM CONTROL METHOD

A commonly chilled water plant includes few parallel chiller units. Each unit comprises of chillers, primary chilled water pump, secondary chilled water pump, condenser water pump, cooling tower unit, and associated control valves [6]. Figs 1 and 2 show chilled water and condenser water systems.

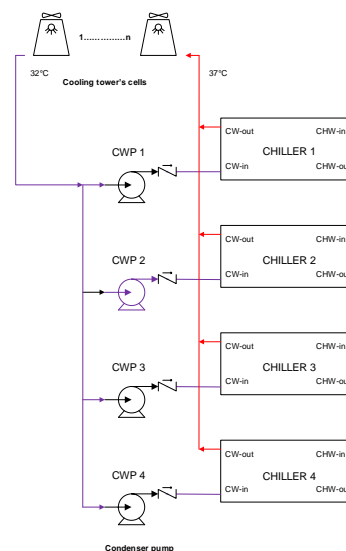

Fig. 1. Condenser water system.

Nguyen Huy Phuong, Phan Quy, and Bui Dang Thanh are with Hanoi University of Science and Technology; 1 Dai Co Viet road, Ha Noi, Viet Nam.

* Corresponding author: Bui Dang Thanh; Tel.: +84 24 3868 3518; fax.: +84 24 3868 3519; Email: uidangthan3i@gmail.com; thanh.buidang@hust.edu.vn.

Each chiller unit in the plant can be sized similarly or dissimilarly. However, due to the maintenance and spare parts cost reason, similar chiller units with their balance of operation are prerequisite requirement of the end users. According to operation requirement, the plant might be at the optimized point if it meets the following conditions:

- The number of staging-up/staging-down chillers, or number of running chiller is optimized
- Each chiller unit is tuning at its optimized point.

2.1 Chilled water supply temperature reset control

Chiller is a complicated machine with high-end technology, especially screw and centrifugal chiller. It comprises of motor, compressor, condenser and evaporator. Each model of chiller comes with a characteristic table of parameters which are tested and analysed to give users the best guidelines for efficiently using.

As other machines, each compressor has owned performance curve in form of pressure load. The pressure load in turn transforms into temperature load of the completed chiller. The deviation between temperature of incoming condenser water and evaporator outgoing ($\Delta T_{Compressor}$) is called compressor’s lift. The chiller operating around the designed best compressor lift outdoor environment and cooling system might give the best performance. This is because operation will affect the condenser water supply temperature, and the demand of building chilled water load affects the return and supply chilled water. The compressor’s lift can be expressed as [2, 7].

$$\Delta T_{Compressor} = CWST - CHWST \tag{1}$$

where CWST is the temperature of incoming condenser water, and CHWST is the temperature of evaporator outgoing.

For a specific chiller used in the building, the best compressor lift is given by manufacturer. Typically, $\Delta T_{Compressor} = 32^{\circ}C - 7^{\circ}C = 25^{\circ}C$. Therefore, the optimize control program can adjust as following:

$$CHWST_{Setpoint} = CWST - \Delta T_{Compressor} \tag{2}$$

In fact, the chilled water supply temperature set point for the chiller cannot to be too low due to the safety of the evaporator coil, but also cannot to be too high due to the inefficiency of the whole HVAC system. We, in this study, use the range from 5°C to 9°C for Hanoi’s climate area.

2.2 Condenser water pump and cooling tower control

According to law of conservation of energy applied to the plant, total plant’s cooling demand of energy is equal to the total plant’s chilled water energy produced and the incoming electric energy consumed by chiller. The chilled water demand in a HVAC system is variable and determined by the user. It means the plant’s cooling demand is also variable. However, there is a rule of self-balancing i.e., whenever the demand leads beyond the cooling capacity, the cooling water supply to the condenser step by step rises up, on contrary it lowers down.

Controlling the whole cooling towers plant and condenser pump group chasing the cooling demand is complicated task. However, we can do control for the condenser water temperature around a desired set point to be more realistic and simpler. The principle is similar to the PID control. If the temperature rises above set point, the program turns more cooling tower cells on and if the temperature is better than the set point, the program can turn cell by cell off.

For the condenser pump, we propose to apply variable frequency drives for all pumps. In theory, the motor’s frequency is proportional to the pump’s round per minute: $RPM = 120 * f / p$, where p is motor’s pole, f is frequency in Hz.

In addition, the relationship between pump’s power, head pressure and flow rate and RPM are:

- Power is proportional to rpm^3
- Head is proportional to rpm^2
- Flow rate is directly proportional to rpm

The relationship between cooling demand and the flow rate as following:

$$Cooling\ demand\ load = k \times F \times \Delta T \tag{3}$$

where k is constant, F is flowrate, ΔT is temperature deviation between input and output of machine.

Therefore, the pump’s frequency is directly proportional, or linear to the cooling demand.

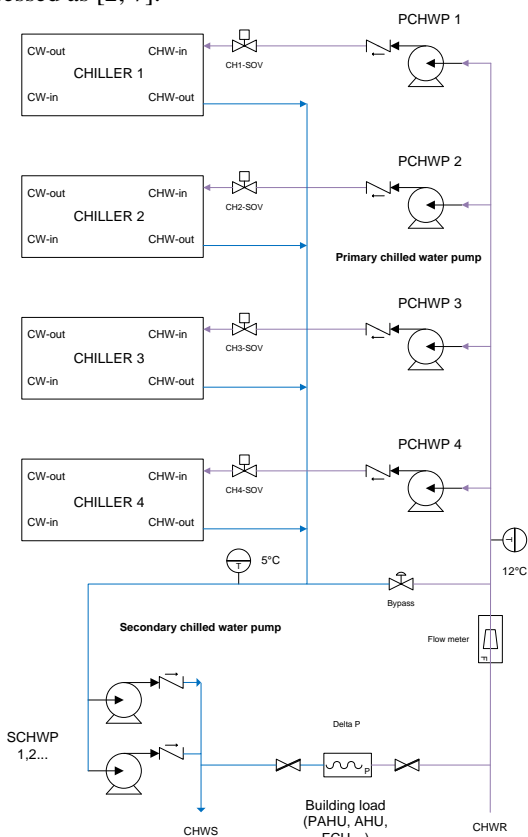

Fig. 2. Chilled water system.

$$HZ_{CWP} = k_{CWP} \times Chiller_{Load} \quad (4)$$

where k_{CWP} is constant.

The chiller manufacturer will provide information as condenser flow rate per capacity, for example 0.0567L/s/kW. We do the investigation of the plant to find the constant value k_{CWP} and used for the optimizing flow rate in the control program.

2.3 Primary chilled water pump control

There are typically two types of primary pump diagram, the primary header system and primary dedicated system, they are controlled as following:

- Primary header system: at least one pump and more in turn to be staged up until satisfying the flow rate demand, the first-in pump will be staged down whenever a smaller number of pumps can do well satisfies the demand.
- Primary dedicated system: each primary pump is dedicated with specific chiller, whenever its chiller stages up or stages down then the dedicated pump follows, except few minutes leading or lagging due to the interlock safety.

Similar to principle of the condenser pump, the frequency of primary pumps is directly proportional to the chiller's load. The given information from chiller manufacturer will provide this information as evaporator flow rate per capacity, for example 0.034L/s/kW. We do the investigation of the plant to find the constant value k_{PCHWP} and used it for optimizing flow rate in the control program.

2.4 Secondary chilled water pump control

The secondary chilled water pump's work principle is to provide the sufficient flow rate to the building HVAC chilled water's user (fan coil unit - FCU, air handling unit - AHU...). On this water circulation system, the chilled water's user at the end of the system, or at the weakest point of the water differential pressure, is not be starved. AHU/FCU have sufficient water pressure at the coil ends to respond to the temperature set point change.

By understanding the principle, executing an investigation of the plant to know exactly the desired differential pressure set point must be taken place. After that we use this value to control those secondary pumps in the optimized control program.

2.5 Optimized start/stop chiller control

Nowadays, there are few types of chiller commonly exists in the building and on the HVAC market, including screw and centrifugal water-cooled chiller, screw air-cooled chiller. Their performances are quite big different; however, with specific plant we can have manufacturer's curve line of coefficient of performance (COP) [8]. From the acquired curve, mathematical calculation or graph shall obviously show the best performance point. For example, Fig. 3 below shows the best performance is lowest point:

Therefore, the optimized control program is designed to stage up/down chiller as long as to make the system's

operation closest to the highest COP or lowest kW/RT (electrical energy consumption index kilo Watt per Refrigeration Ton). The program decision has based on the current chiller plant's load and information of each chiller.

3. SYSTEM DESIGN

The optimized control program uses software program modules for executing control flowcharts. A main control program will coordinate and calling each of modules. Therefore, the software will be flexible, easy to troubleshoot, and be upgraded.

3.1 System hardware diagram

In this study, we develop the application based on Building Management System (BMS) Apogee Insight of Siemens, the system architecture includes:

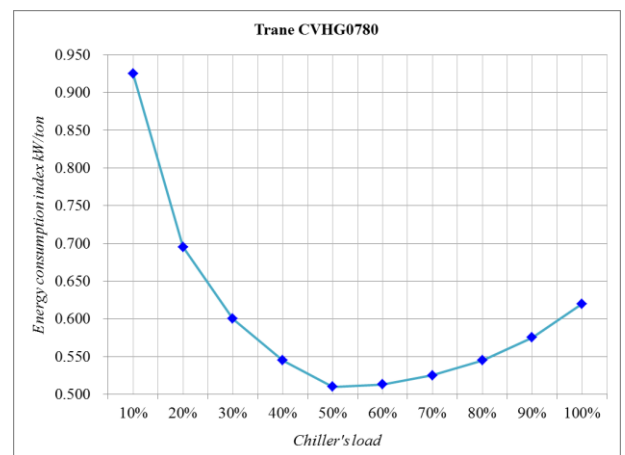

Fig. 3. CVHG0780 energy performance curve.

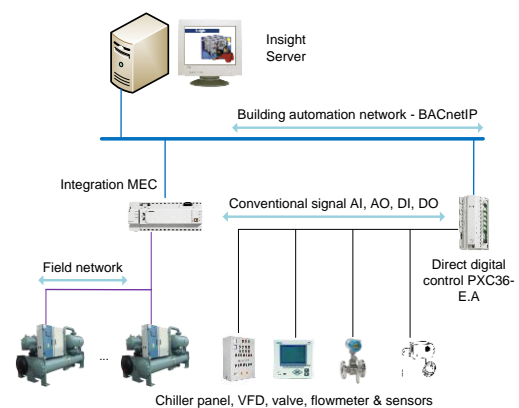

Fig. 4. System architecture for chiller plant.

- Integration controller MEC, which is responsible for integrate chillers or variable frequency drives' networks with the BMS building automation network, this is high-level integration enable software module to control and monitor chiller's condition as well as to send the chilled water supply temperature to the chiller timely.

- Direct digital controller PXC36-E.A, which is responsible for monitor and control other plant's devices by connecting (via conventional signal AI, AO, DI, DO) to sensors, actuators or electrical motor panels.
- A server installed Insight version 3.13 cum human machine interface, which store and execute the software program and control graphics for operators use. All are connected on a building automation network shown in Fig. 4.

3.2 Staging up/down module

The flowchart of Staging up/down module and Optimized start/stop module are presented in Fig. 5 and 6, respectively.

3.3 Chilled water supply temperature reset

The chiller's temperature set point is calculated by program and sending to chiller as in [6]. There are both limited point for low and high temperature.

3.4 Secondary pump flow control

To find out the starved point of the chilled water user, we need to investigate the actual running HVAC system [9, 10]. After that we used collected information to give set point to PID controller of pump frequency. Fig. 7 shows a well responding FCU temperature when the temperature set point is lower down due to owner's requirement.

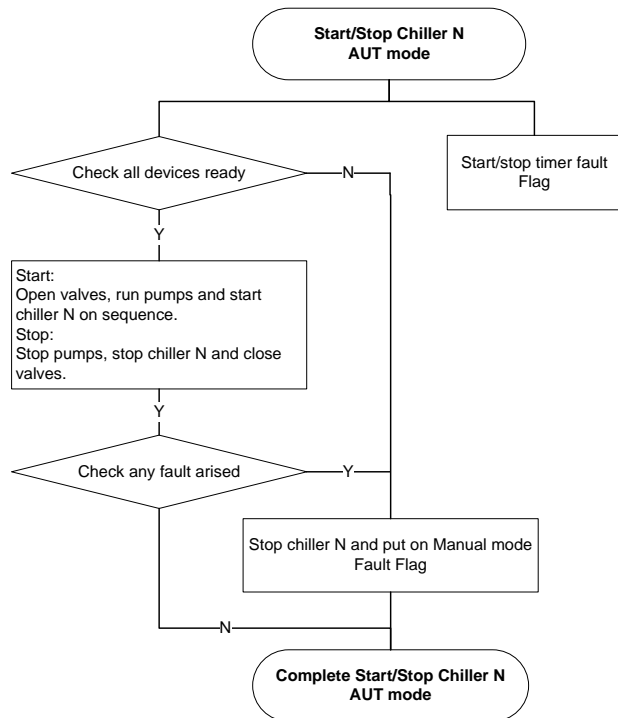

Fig. 5. Staging up chiller flowchart.

3.5 Optimized start/stop module

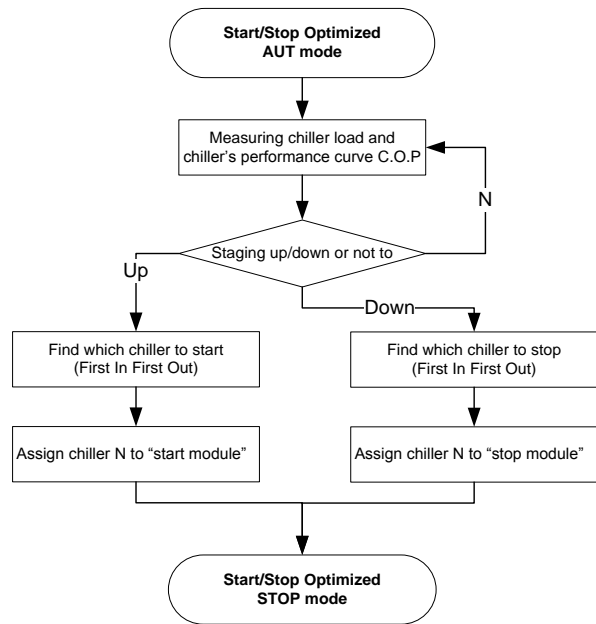

Fig. 6. Optimized start/stop flowchart.



Fig. 7. Trending FCU set point change.

3.6 Condenser pump and cooling tower control module

The condenser water pump frequency is controlled via variable frequency drive to optimize the flow according to the condenser load required. Besides, the cells are on or off as shown in Fig. 8.

4. EXPERIMENTAL RESULTS AND DISCUSSION

We applied our approach in a Hotel- Office-Resident complex in Hanoi. The chilled water production plant has been operated by an existing Siemens building management system that was not optimized. In this experiment, we use index of HVAC sector kWh/Btu to evaluate the optimized control program. The kWh/Btu index means the amount of energy that the plant needed to generate one thermal unit in Btu.

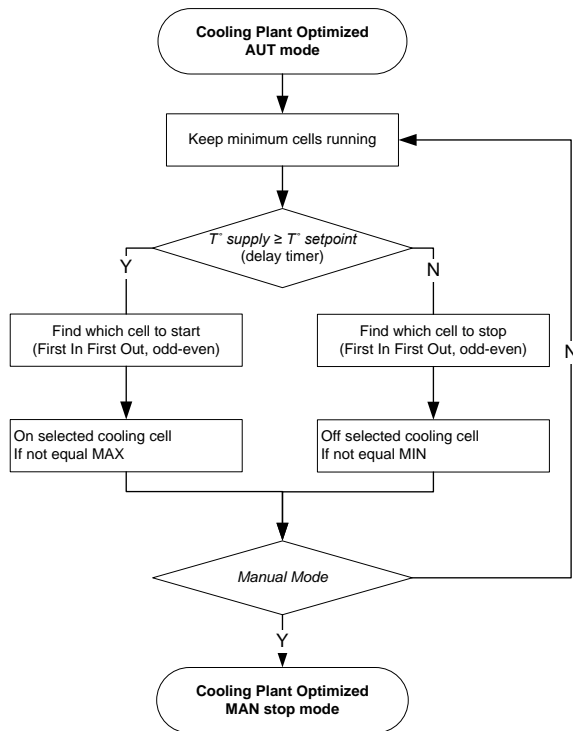

Fig. 8. Cooling cell's operation flowchart.

Table 1. Average energy before and after using control program

Average Temp	Average kWh/Btu index		Energy saving
	Before use	After use	%
22 °C	79.04	-	-
23 °C	74.65	-	-
24 °C	70.84	62.64	11.6%
25 °C	71.05	63.04	11.3%
26 °C	67.78	63.37	6.5%
27 °C	66.64	61.40	7.9%
28 °C	68.20	61.95	9.2%
29 °C	66.08	60.79	8.0%
30 °C	67.61	61.22	9.5%
-	-	-	9.1%

Temperature is round off upto 1 °C

We have collected the chilled water production plant operation's kWh and the generated thermal Btu before running and after using control program. Those data were recorded with the witness of owner and building operation team. The performances kWh/Btu are compared in couple of days which have similar environment temperature and building load. The data is presented in Table 1. In addition, Fig. 9 gives us visual information about energy efficiency saving of the plant before and after optimized. The kWh/Btu index is scaled 106 times.

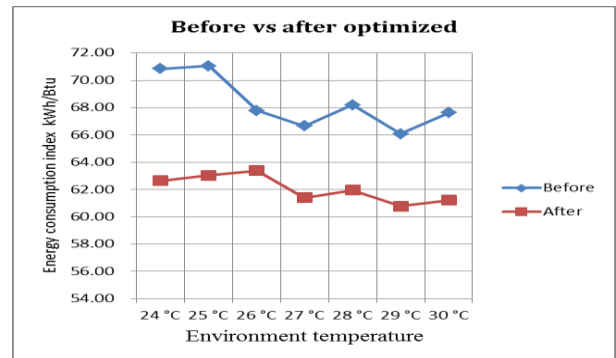

Fig. 9. Comparing energy efficiency.

5. CONCLUSION

We have designed a system and control software for a central chiller plant. The proposed approach not only optimizes the start of equipment but also adjust the machine's parameters and set points. The combination of optimal parameters automatically calculated by control program making the system possesses higher efficiency than the case used a single parameter. The tested data from high-rise building shows the control method is applicable. The next step of the research will test the optimized control program on the air-cooled chilled water plant.

REFERENCES

- [1] Sun, Y., Sun, Y., Li, J. 2009. Design of Automation Control System for Water Chillers, *In Proceedings of the Fourth International Conference on Innovative Computing, Information and Control*, Kaohsiung, Taiwan, 7-9 December, pp. 556-560.
- [2] BCA Singapore, 2015. BCA Building Energy Benchmarking Report 2014, International Green Building Conference.
- [3] Building energy data book, technical report, U.S Department of Energy, 2009.
- [4] Torzhkov, A., Sharma, P., Li, C., Toso, R., Chakraborty, A., 2010. Chiller Plant Optimization-An Integrated Optimization Approach for Chiller Sequencing and Control, *In Proceedings of the 49th IEEE Conference on Decision and Control*, Atlanta, GA, USA, 15-17 December.
- [5] Bui, DT., Nguyen, LD., Journet, B., 2009. Improving the behavior of an electro-optic modulator by controlling its temperature, *In Proceedings of the 2009 International Conference on Advanced Technologies for Communications*, Haiphong, Vietnam, 12-14 October, pp.125-128
- [6] Zhang, D., Luh, P., Fan, J., Gupta, S., 2018. Chiller Plant Operation Optimization: Energy-Efficient Primary-Only and Primary-Secondary Systems, *IEEE Transaction on Automation Science and Engineering*, vol. 15, no. 1, pp. 341-355.
- [7] Erpelding, B., 2008. Monitoring Chiller Plant Performance, *ASHRAE Journal*, 2008.
- [8] AHRI Standards 550/590 (I-P)-2015 & 551/591 (SI)-2015, 2015. Air Conditioning, Heating and Refrigeration Institute, USA.

- [9] Hacker, D., Schroeder, K., 2009. Variable Volume Chilled Water Pumping System Controls, *Dayton ASHRAE presentation*.
- [10] Steven T., Taylor, P. E., 2011. Optimizing Design & Control of Chilled Water Plants, *ASHRAE Journal*.